

**YOUR VISION
OUR MACHINES**



BAND SAW
Elite 65BS

AMUZMA[®]



Precision and Power in Every Cut.

The 16" Elite 65BS Bandsaw is built for industrial strength, featuring a heavy-duty welded frame, 35mm blade support, and up to 20,000 PSI tension. Achieve fast, clean, high-precision cuts—perfect for resawing and high-volume production.

SPECIFICATIONS

Blade Specifications		Motor Power Output	4kW S1
Blade Length	4470 mm	Brake	
Blade Width	10-35 mm	<input checked="" type="checkbox"/> Foot Brake	
Blade Speed	1500 m/min	<input type="checkbox"/> Magnet Motor Brake	
Max Depth of Cut		Extractor Port Diameter	2×100 mm
<input checked="" type="checkbox"/> With bearing guide.	370 mm	Net/Gross Weight	323/359 Kgs
<input type="checkbox"/> With European style roller guide	370 mm	Wood box dimensions	
Throat Width	580 mm	HxLxW	1119 x 777 x 2070mm
Table Size	700×608 mm	Dimensions	
Table Tilt	0-20°	HxLxW	2017 x 1201 x 889mm
Band wheel Diameter	610 mm		

Standard Equipment Optional Equipment

ACCESSORIES



Lower Blade Guides



Upper Blade Guide & Guard



Miter Gauge



Band Saw Wheel (Flywheel)

DIMENSIONS

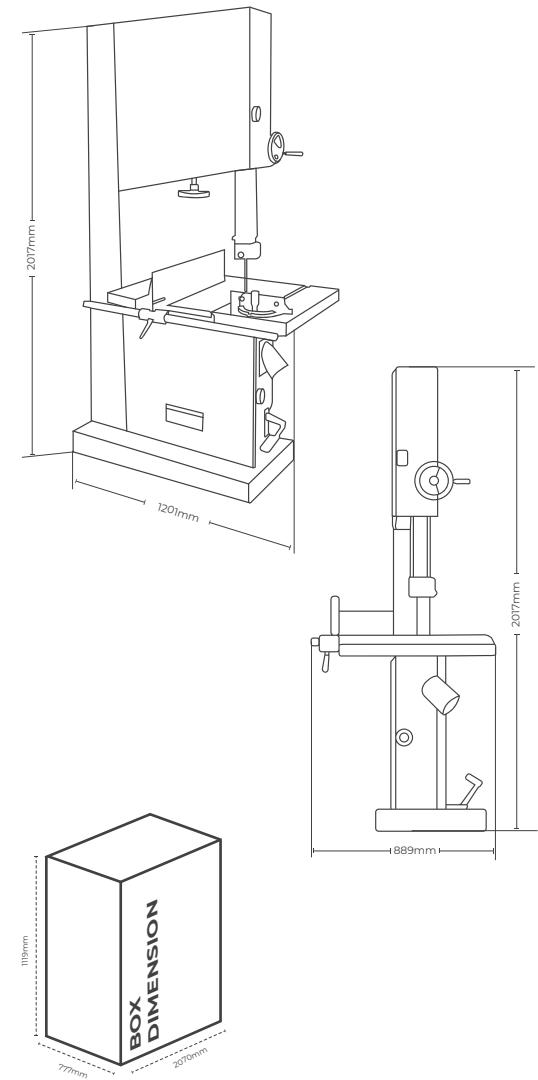

Contact Us

 +971 45478088

 +971 50 857 6840

 info@amuzmamachinery.com

 www.amuzmamachinery.com

 Ras Al Khor, Industrial Area 2,
United Arab Emirates



Website



Contact Us