



**YOUR VISION
OUR MACHINES**



PANEL SAW
Elite 35TS

AMUZMA®



Compact Power, Precision Cutting

This heavy-duty panel saw is specifically engineered for small spaces, allowing workshops with limited footprints to achieve full-sized performance. Built with a cast iron table and a robust steel frame, the machine provides the stability and strength required for professional-grade durability. It is designed to deliver smooth, accurate cuts consistently, making it a perfect and versatile solution for processing both panels and solid timber.

SPECIFICATIONS

Blade Specifications

Main Blade Diameter 315 mm

Main Blade Speed 4500 rpm

Scoring Blade Diameter 120 mm

Scoring Blade Speed 8000 rpm

Blade Tilt 0-45°

Max Depth of Cut @ 45° 67 mm

Max Depth of Cut @ 90° 95 mm

Max Rip Capacity

■ Standard 900 mm

□ Option 1250 mm

Sliding Beam Size

■ Standard 1200 × 360 mm

□ Option 1600 × 360 mm

Sliding Beam Cutting Capacity

■ Standard 1250 mm

□ Option 1600 mm

Table Size 800 × 530 mm

Dust Extraction Outlet 120 mm

Main Motor Output:

3*400V 4kW SI

3*400V 2.5kW SI

3*400V 5kW SI

1*230V 3kW SI

Scoring Motor Output 0.75kW SI

Net/Gross Weight 400/460 kgs

Package Size 1300 × 1000 × 1100 mm

Dimensions

L x W x H 2550 × 920 × 860 mm

■ Standard Equipment □ Optional Equipment

ACCESSORIES



Crosscut Miter Fence



Blade Tilt Handwheel

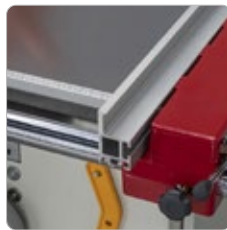

Rip Fence with Micro-Adjustment Mechanism



Sliding Table with End with Tool Tray

DIMENSIONS

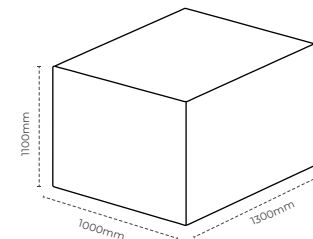
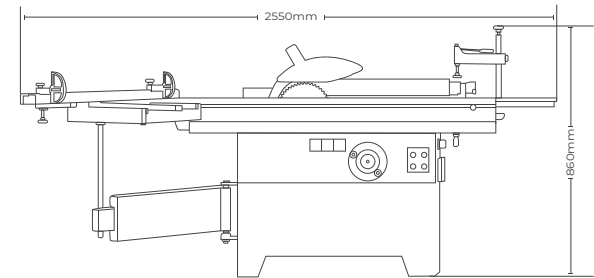
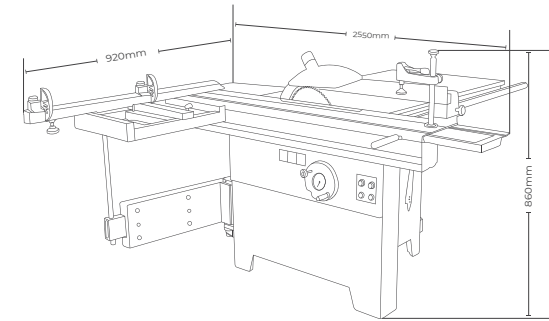

Contact Us

 +971 45478088

 +971 50 857 6840

 info@amuzmamachinery.com

 www.amuzmamachinery.com

 Ras Al Khor, Industrial Area 2,
United Arab Emirates



Website



Contact Us