



YOUR VISION
OUR MACHINES



PANEL SAW
Firma 35PS

AMUZMA®



Compact Power for Precision Cutting

The Firma 35PS is a space-saving, high-performance panel saw built for small to mid-sized workshops. Despite its compact size, it offers full-scale industrial precision, effortlessly cutting panels up to 3200mm. Ideal for furniture, cabinetry, and woodworking, it features a motorized blade rise for smooth, efficient operation.

SPECIFICATIONS

Main Blade Diameter	315 mm	Blade Tilting	
Main Blade Speed	4500 rpm	Standard	Manual Tilting
Scoring Blade Diameter	120 mm	Option	Motor Tilting
Scoring Blade Speed	8000 rpm	Table Size	800(530+820) mm
Blade Tilt	0-45°	Dust Extraction Outlet	120mm
Max Depth of Cut @ 45°	67 mm	Main Motor Output	
Max Depth of Cut @ 90°	95 mm	3*400V	5kW SI
Max Rip Capacity	1250 mm	3*400V	4kW SI
Sliding Beam Size		Scoring Motor Output	0.75kW SI
<input checked="" type="checkbox"/> Standard	3200×360 mm	Net/Gross Weight	560/680kgs
<input type="checkbox"/> Option	2200/2600/3800×360 mm	Package size	
Sliding Beam Cutting Capacity		Pallet	2300×1080×1150/3615×480×210 mm
<input checked="" type="checkbox"/> Standard	3200 mm	Wood box	2300 X 1160 X 1160/3615×480×210 mm
<input type="checkbox"/> Option	2200/2600/3800 mm	Dimensions	
Blade Raising		L	6700 mm
<input checked="" type="checkbox"/> Standard	Manual Rised	W	3900 mm
<input type="checkbox"/> Option	Motor Rised	H	1510 mm

Standard Equipment Optional Equipment

ACCESSORIES



Sliding Carriage Handle and Control Panel



Main and Scoring Blade Assembly



Manual Handwheel for Blade Tilt



Sliding Table Carriage End Grip

DIMENSIONS

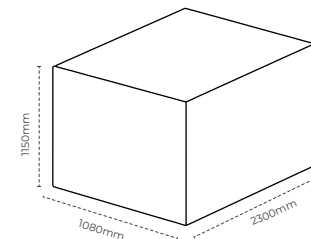
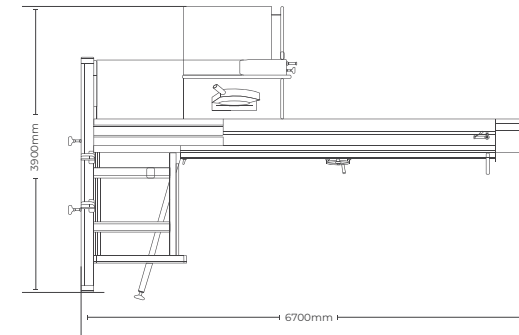
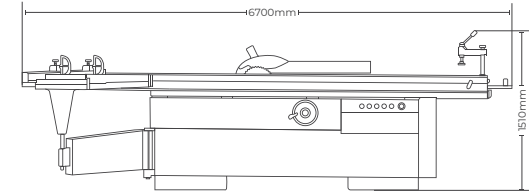

Contact Us

 +971 45478088

 +971 50 857 6840

 info@amuzmamachinery.com

 www.amuzmamachinery.com

 Ras Al Khor, Industrial Area 2,
United Arab Emirates



Website



Contact Us